

VS/VSR/INJ Assembly Manual



<u>Table of Contents:</u>	<u>Page</u>		<u>Page</u>
System General operation	2	Bleeding/Priming System	8
Continuous Application	2	Fill Lubricant Lines	8
Pulsed Application	2	INJ/VS/VSR Model Code	9
Control Configuration	3	Injector Description/Operation	10
VS Manifold Assembly	4	VS Assembly Breakdown	11
Dual Regulator	5	INJ/VS/VSR Tech Data	12
INJ assembly	6	INJ/VS/VSR Spare Parts List	13
VSR Assembly	7	VS/VSR Cable Assemblies	14
Tube Connections	8	Sample Electrical Diagrams	15-16

System General Operation:

Inlet air supply flows through a 5 micron filter/regulator assembly and is controlled by two integrated solenoid valves. One valve (injector valve) is used to supply air pressure to a positive displacement injector. The remaining air valve (nozzle valve) feeds a regulator, which in turn provides air to the downstream nozzle assembly. The positive displacement injector has a known volume and when pressurized (“fired”), lubricant is dispensed out of the metering chamber, through the injector check valve and into the downstream nozzle oil line. Each style of nozzle has an integral check valve which maintains pressure within the oil line between the system and the nozzle assembly.

Internal porting within the nozzle assembly allows the regulated air supply to mix with the oil supply in a precision mixing chamber downstream of the nozzle check valve. It is at this point the air acts as a transport media, shearing the oil into large droplet formations then “carrying” the oil from the nozzle outlet to the object to be lubricated. The injector valve is cycled “on/off” with a minimum “on” time of 0.5 seconds (1 Hz.). When the injectors are cycled at a fast rate a thick film of oil is produced on the inner walls of the mixing cavity and nozzle tip. When air is introduced the oil migrates along the inner walls and the result is a thick continuous pattern of oil. When the injectors are cycled at a slow rate the film thickness is reduced, resulting in a thinner pattern of oil.

The VS manifold assembly system was designed to function according to (2) different lubrication applications: “Continuous” or “Pulsed”.

Continuous Application

This is the most common application where the application of lubricant is applied in a “continuous” fashion. The above mentioned nozzle valve is supplying a constant flow of air to the nozzles while the injectors are cycled at the desired rate, resulting in a continuous pattern of lubricant. Nozzle types used for these applications are of the Swivel style (i.e. SWN, SFN, STN), where the check valve assembly is located within the body of the nozzle assembly (creating a larger mixing chamber).

Pulsed Application

This application is predominantly used for assembly processes (i.e. engine assembly), but can also be used for lubricating slow moving chains or overhead trolley wheels. For this application the nozzle air valve is cycled at the same rate as the injector valve, where the “off” time would coincide with the speed of the assembly line or conveyor. This type of application utilizes a “Tube-Type” nozzle assembly (i.e. TPN, TFN, TCN), where the check valve is located at the end of the nozzle tip, resulting in a smaller mixing cavity to immediately transfer the dispensed lubricant to the object.

Control Configuration:

Below is a brief description of control requirements necessary to properly run the VS assembly.

Definitions:

DWELL TIME: Duration that the injector valve is activated.

OFF TIME: Duration that the injector valve is deactivated.

INJECTOR CYCLE TIME: Duration of complete cycle (i.e. Cycle Time = Dwell Time + Off Time)

- 1). Constant power supply for level and pressure switch fault indicator.
(Reference system prints for power requirements.)
- 2). Injector air valve timing signal. Signal should be cycled “On/Off” according to the timing diagram shown in Fig. 1. (Note: Dwell time should be set for a minimum time of 0.5 seconds.)
- 3). Nozzle air valve signal. (Dependent upon application, reference Fig. 1)

Reference print #570-89499 for solenoid cable detail.

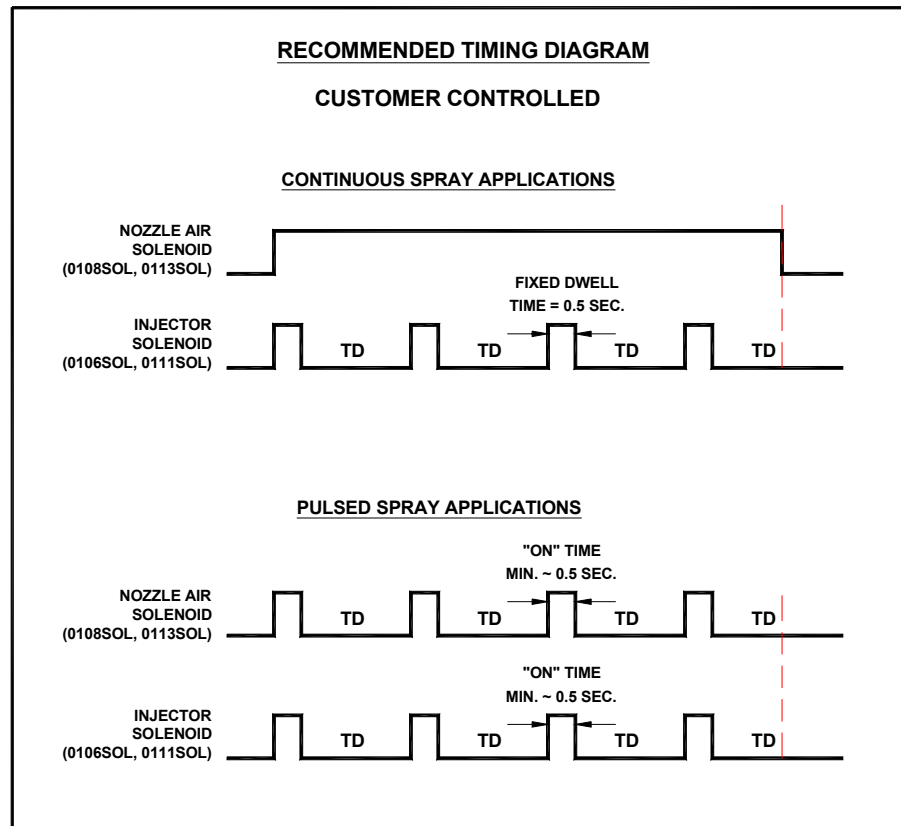

Fig. 1: Timing configuration for VS Manifold Assembly

VS Manifold Assembly

The VS Manifold assembly is a self contained modular unit that incorporates solenoid valves to control the injector air supply as well as the regulated air supply for the nozzle assembly (Ref. Fig. 2).

- a). Injector Solenoid valve (1): This is the first valve in the stack and its sole purpose is to provide a pulsed air signal to the injector.
- b). Nozzle air solenoid valve (2): The next valve in the manifold stack is responsible for supplying main air pressure to the neighboring component, the regulator block.
- c). Regulator block (3): Accepts main air pressure from the nozzle air solenoid valve and regulates the pressure down to an acceptable level for the nozzle assemblies. The outlet of the regulator block is ported through all the following components.
- d). The following block is the oil feed block (4), receiving oil from the reservoir and feeding all following injectors.
- e). The Injector block (5) mainly consist of a positive displacement injector. The pulsed air signal (from the injector solenoid valve) drives a piston-pin assembly forward into an oil-metering chamber. The piston-pin assembly pressurizes the oil, overcoming an integral outlet check valve assembly and oil is dispensed (reference Injector operation section for more information). The injector block is also ported for the regulated nozzle air supply.
- f). The manifold end plate (6), contains the bleed pet-cock (7) and auxiliary ports to run both the injector air signal and the nozzle air supply to an external injector assembly.

Fig. 2: VS Manifold Single Network, Single Regulator Assembly with Six Injectors

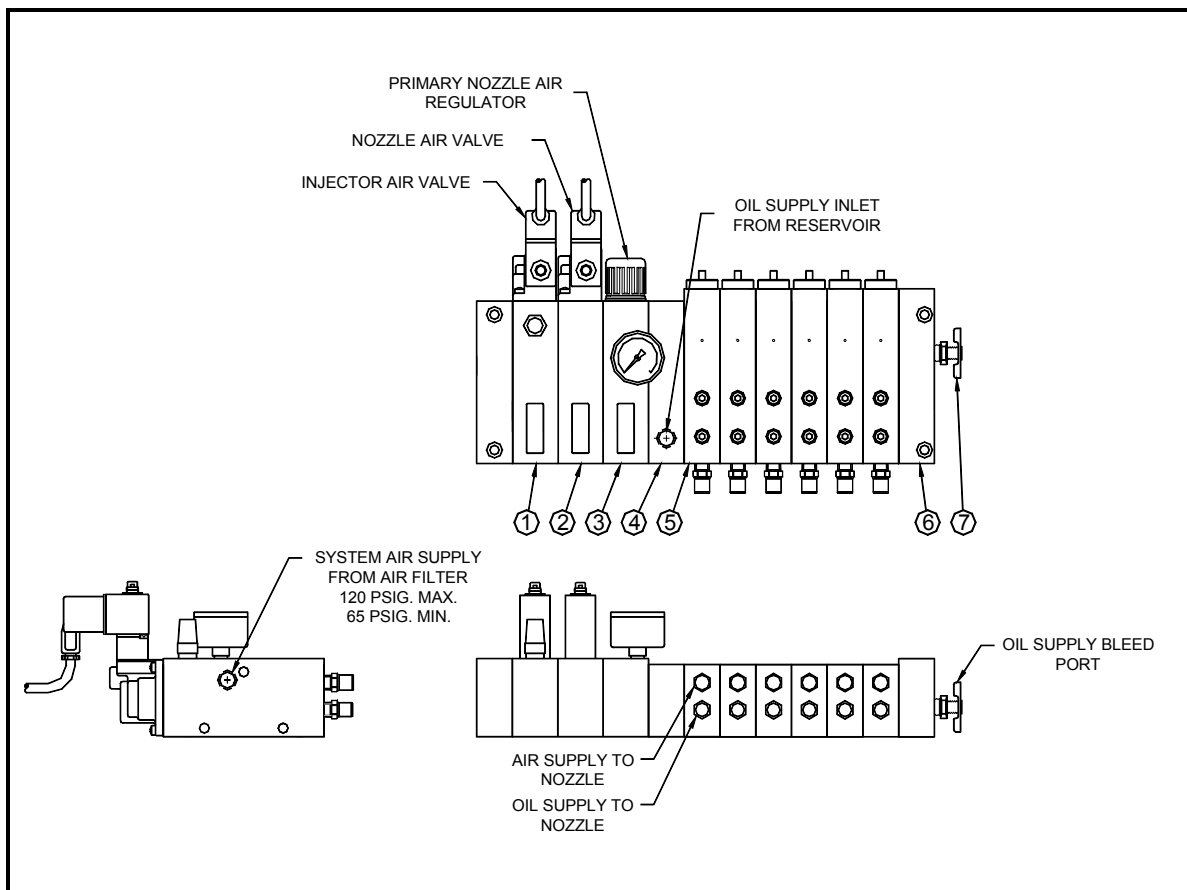
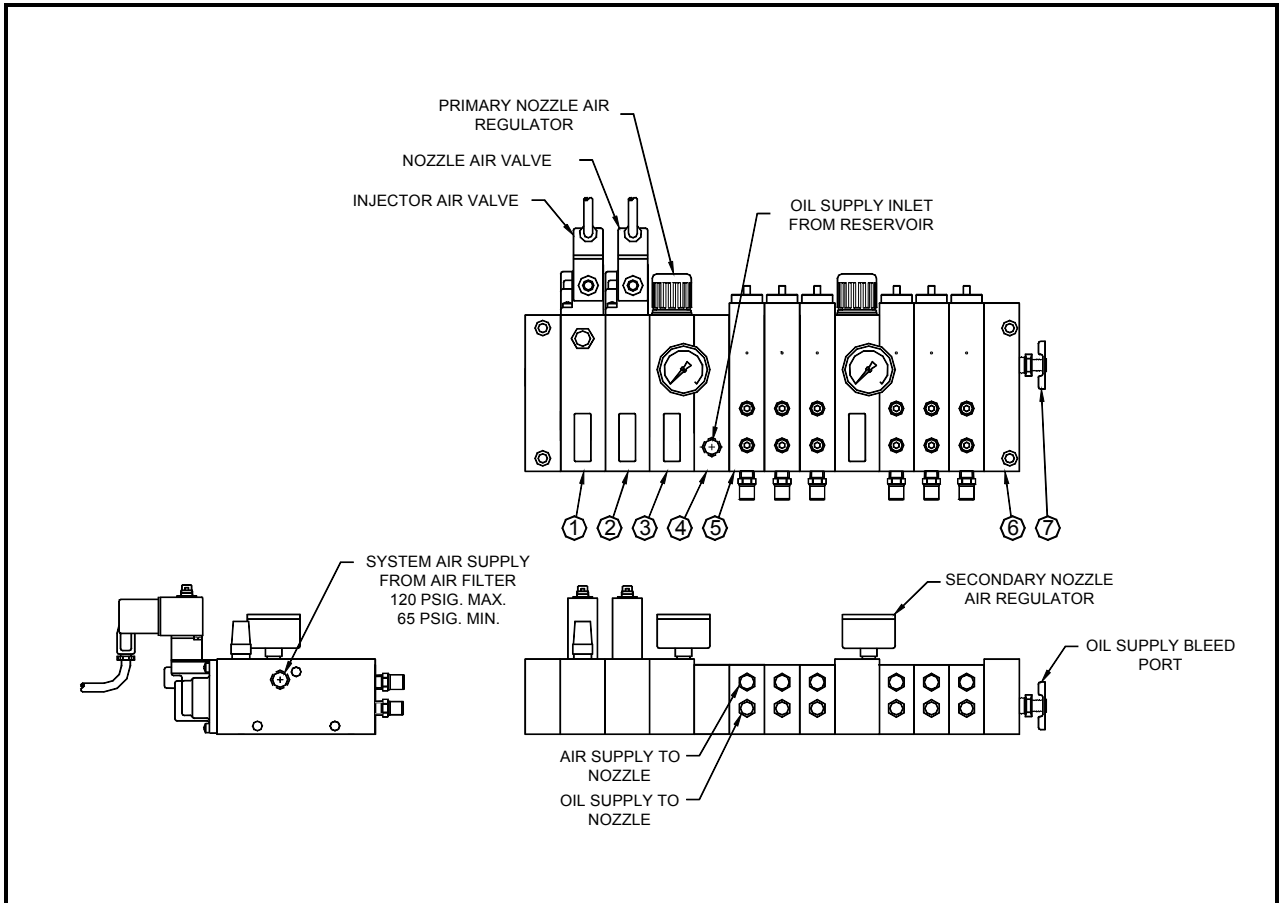
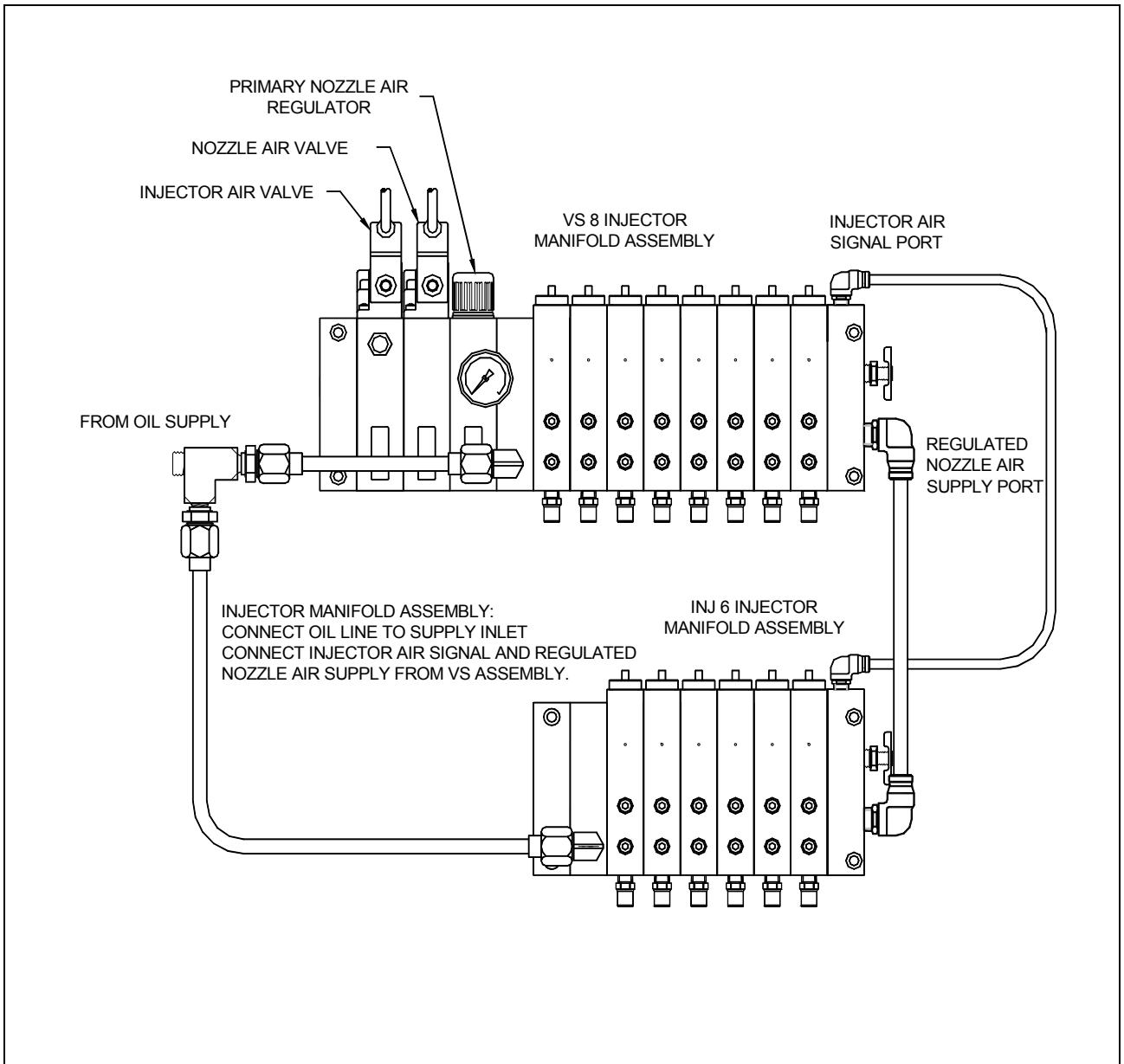

Fig. 3: VS Manifold Single Network, Dual Regulator Assembly with Six Injectors



The VS manifold can accommodate applications that require various nozzle air pressures. A sample dual regulator configuration is shown in Fig. 3. The sole purpose of the regulator is to provide the nozzles a regulated air supply. In this configuration the primary regulator is used to provide the nozzle air pressure for the first three injectors. Since both regulators are supplied directly from nozzle air valve, the secondary regulator provides the nozzle air pressure for the remaining three injectors, independent of the primary regulator.

**Fig. 4: VS Manifold Single network, Single Regulator Assembly with Eight Injectors
INJ Manifold Assembly with Six Injectors**



For applications requiring more than eight injectors, the VS manifold end cap can be utilized to run the injector air signal and the regulated nozzle air supply to an additional bank of injectors.

Fig. 5: VSR Assembly w/ Manual Fill Reservoir and VS Manifold assembly with Eight Injectors

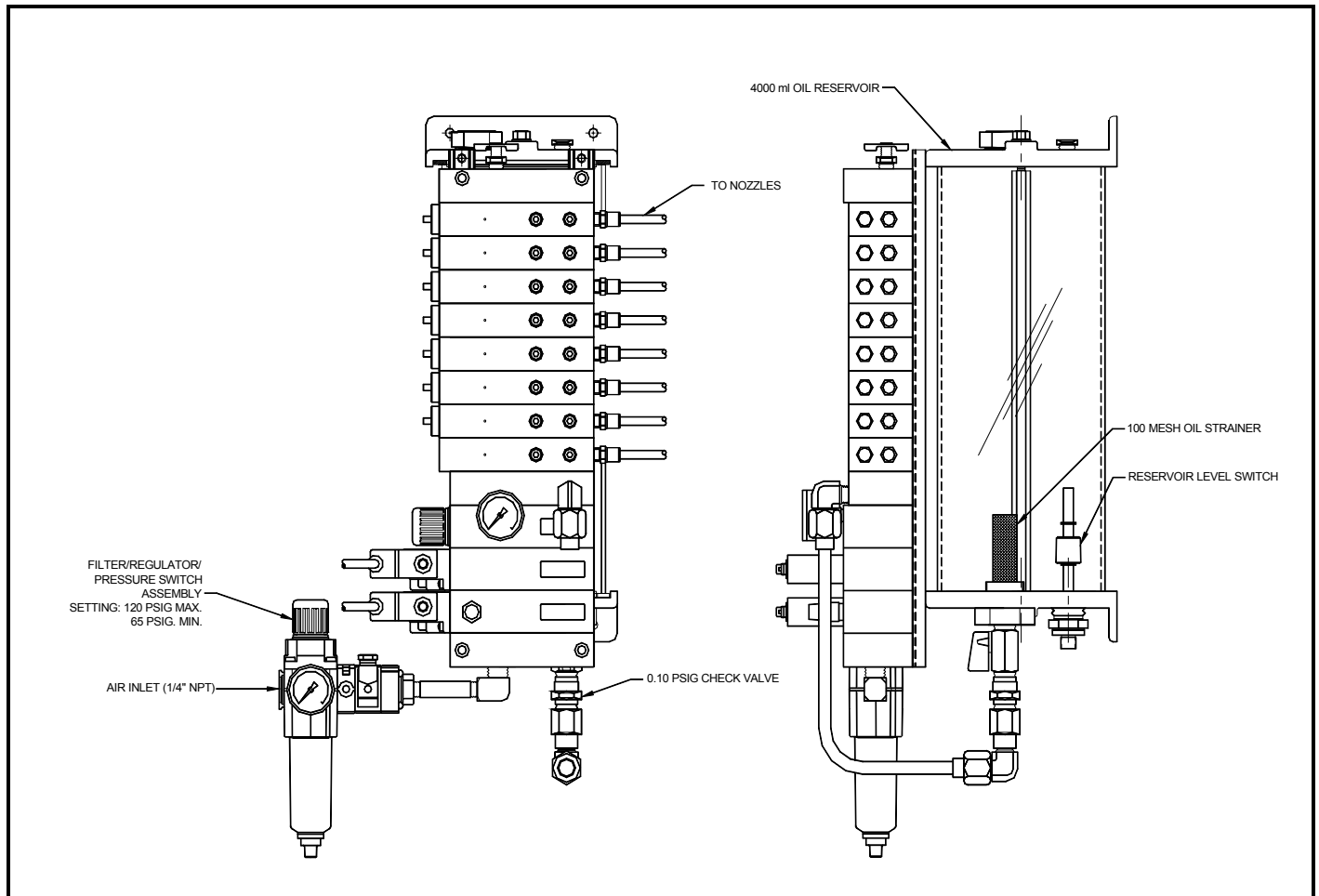

VSR Assembly

The VSR assembly contains the modular VS Manifold integrated with a 4000 ml oil reservoir and a filter/pressure switch assembly. The reservoir contains a low level switch and integral oil strainer (100 mesh) with a check valve on the outlet to prevent back flow from the VS assembly to the reservoir.

Tubing Connections: Reference system part number for type of tubing.

Nylon Tubing:

- Lubricant line: 3/16" O.D.
- Nozzle air supply: 1/4" O.D. (3/8" O.D. for spindle applications)
- Ensure that the tube end is cut square and free from burrs.
- Push the tube end through the collet into the fitting.
- Continue pushing the tube firmly through the O-ring until it bottoms out on the tube stop, then pull back.
- To disconnect, push the tube into the fitting until it bottoms out on the tube stop. Then, while holding down the collet, withdraw the tube.
- Run feed lines from the system to the nozzle assembly in such a manner to avoid damage due to friction or vibration.
- Do not connect the feed lines at this time.

Steel Tubing:

- Cut tubing square with a tube cutter or fine-tooth hacksaw.
- Lightly deburr the I.D. and O.D. of the tube end to remove burrs and sharp edges.
- Slip nut and ferrule over deburred tube end. Be sure the long, straight end of the ferrule points toward the tube end.
- Hold tube steady against internal shoulder of fitting body and tighten nut.
- Loosen nut and check for proper set (i.e make sure ferrule is secured to tube). Avoid rotating the ferrule.

Bleeding/Priming System:

- Set VS manifold assembly air regulator to 0 psig.
- Open the ball valve (located on the reservoir bottom plate) to allow lubricant to fill the system. Note: Handle on the ball valve should be inline with the tubing.
- Open the bleed pet-cock valve, located on the VS manifold assembly end cap.
- Allow oil to drain until air is no longer present, then close pet-cock.
- Manually cycle the injectors: Push in on the injector adjustment cap, starting with the injector closest to the oil feed block. Repeat until lubricant is observed in the nozzle feed line.
- Repeat process to each injector.

Fill Lubricant Lines:

- Cycle system until lubricant reaches nozzle position.
- Continue to cycle (to purge tubing of all contaminants).
- Monitor progress. Note: If injectors are not delivering, repeat bleed process.
- With the system cycling, adjust the air regulator to 5 psig.
- Continue cycling system until lubricant is dispensed out nozzle tip.
- Adjust air regulator to ensure acceptable spray pattern for all nozzle assemblies.

“How to Order” – VS & VSR Lubrication System

Continuous & Pulse Spray Applications

	VS	S	H	IL	NY	M
Product Type						
Valve Stack Without Reservoir	VS					
Valve Stack With Reservoir	VSR					
Injector Stack (No Controls).....	INJ					
Control Type (Electrical/Pneumatic/Connector Timer)						
120 VAC	A					
220-240 VAC, 50/60Hz	B					
24 VDC (European Version)*--see below	C					
24 VDCD						
Pneumatic Controls)	P					
No Solenoid (INJ only).....	X					
Millennium Timer Options {connector timer} Operating Range						
(1) MCT 120V; (2) MCT 240V; (3) MCT 24VDC (2.1 to 200 seconds)						
(4) MPT 120V; (5) MPT 240V; (6) MPT 24VDC (0.5 to 5 seconds)						
(7) MCT 120V; (8) MCT 240V; (9) MCT 24VDC (4 to 400 seconds)						
Substitute the number for the letters above for electrical options.						
Regulator						
Single Regulator	S					
Dual Regulator	D					
Split Option	W					
No Regulator (INJ only)	X					
Injector Size						
Half-Drop Injector	H					
Two Drop Injector	T					
Combination of “H” & “T” injectors	B					
Number Of Injectors						
Range from “1” to “8”						
Regulator Options						
One Regulator	X1					
Two Regulators - # of injectors/regulator						
<i>(first digit/first regulator; second digit/second regulator)</i>						
No Regulators (INJ Only).....	XX					
Split Option – Spray Nozzles/Drip Nozzles						
<i>{must have “W” option in regulator field}</i>						
Half & Two Drop Injectors - respectively.....						
<i>{first digit/half drop injectors; second digit/two drop injectors – must have “B” in the injector field}</i>						
Fitting Location						
In-Line Location	IL					
Low-Profile Location	LP					
No Fittings	XX					
Type Of Fitting						
<i>(Oil Lines: Nylon: 3/16” O.D. Tubing Steel Tube: 1/8” O.D. Tubing)</i>						
<i>(Air Lines: Nylon/Steel: 1/4” O.D. Tubing)</i>						
Nylon Push In Fittings.....	NY					
Nylon Compression Fittings	NC					
Steel Tube Fittings: Carbon Steel	CS					
Steel Tube Fittings: Stainless Steel	SS					
No Fittings	XX					
Reservoir Fill Options {omit for VS or INJ product}						
Manual Fill	M					
Central Fill	P					
Manual Fill/High Level Switch.....	MH					
Central Fill/High Level Switch	PH					
<i>{low-level feedback is a standard in all reservoirs except pneumatically controlled version}</i>						

* DIN 43650 (LED & Surge Suppressor) solenoid connectors with metric tube fittings.

Model 570-10000 Half-Drop Injector (0.015 ml) Model 570-10002 Two-Drop Injector (0.060 ml)

SPECIFICATIONS

Lubricant viscosity range: 100-2000 SUS
 Operating pressure (air): 65-120 psi (4.5-8.3 bar).
 Operating pressure (oil): 200 psi max. (8 bar)
 Pumping ratio 40:1 (theoretical) for 570-10000, 10:1 (theoretical) for 570-10002
 Output volume (oil):
 570-10000: 0.015ml/cycle (0.001 in³)
 570-10002: 0.060ml/cycle (0.004 in³)
 Maximum speed: 120 cpm (2 Hz)
 Outlet port size oil & air: 1/8 NPTF
 Monitor port size oil & air: 1/8 NPTF

DESCRIPTION

The Orsco Injector serves a multi-function purpose of dispensing and monitoring both air and oil to the spray nozzle. Due to the stackable modular design there has been a significant reduction in the amount of tubing and connectors necessary to assemble the unit.

OPERATION

As air enters the upper piston area "A" it pushes the piston/plunger downward due to the ambient pressure below the piston. When the piston/pin assembly moves downward the oil in the pumping chamber "B" is pressurized to overcome the outlet check spring "C" and oil is dispensed. When the pressure is vented from the top of the air piston "A", the piston return spring "D" pushes the piston/pin assembly back to the return position. As the piston assembly returns, the outlet check closes creating a vacuum in the pumping chamber "B". When the pin returns beyond the oil inlet hole "E", lubricant flows into the volume chamber completing the cycle.

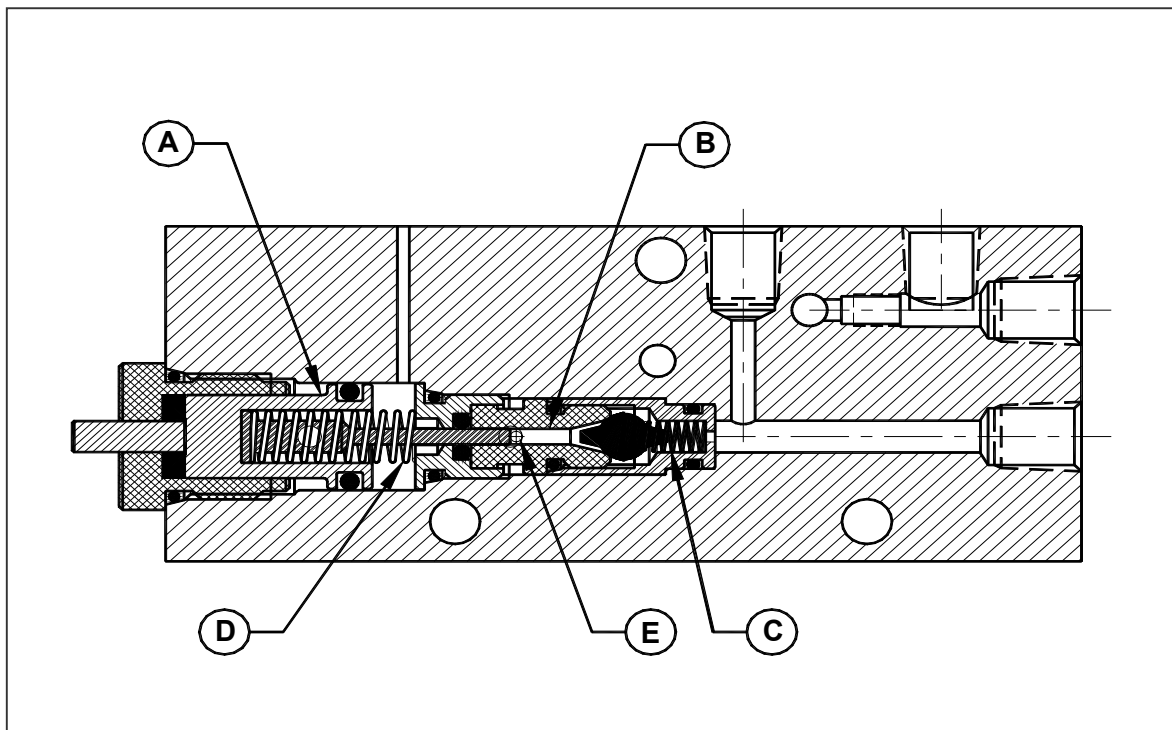

Lubrication Systems

VS Assembly: Adding or replacing an injector

- 1). Remove #10-32 B.H.C.S. from Injector End Cap.
- 2). Remove Injector End Cap.
- 3). To replace injector, simply remove existing injector and replace with new (ensure seals are seated properly).
To add an injector, thread one injector tie-rod (three req'd per injector) onto each existing tie-rod assembly.
Install additional injector (ensure seals are seated properly).
- 4). Install Injector End Cap. Install #10-32 B.H.C.S..
- 5). Re-bleed VS assembly.

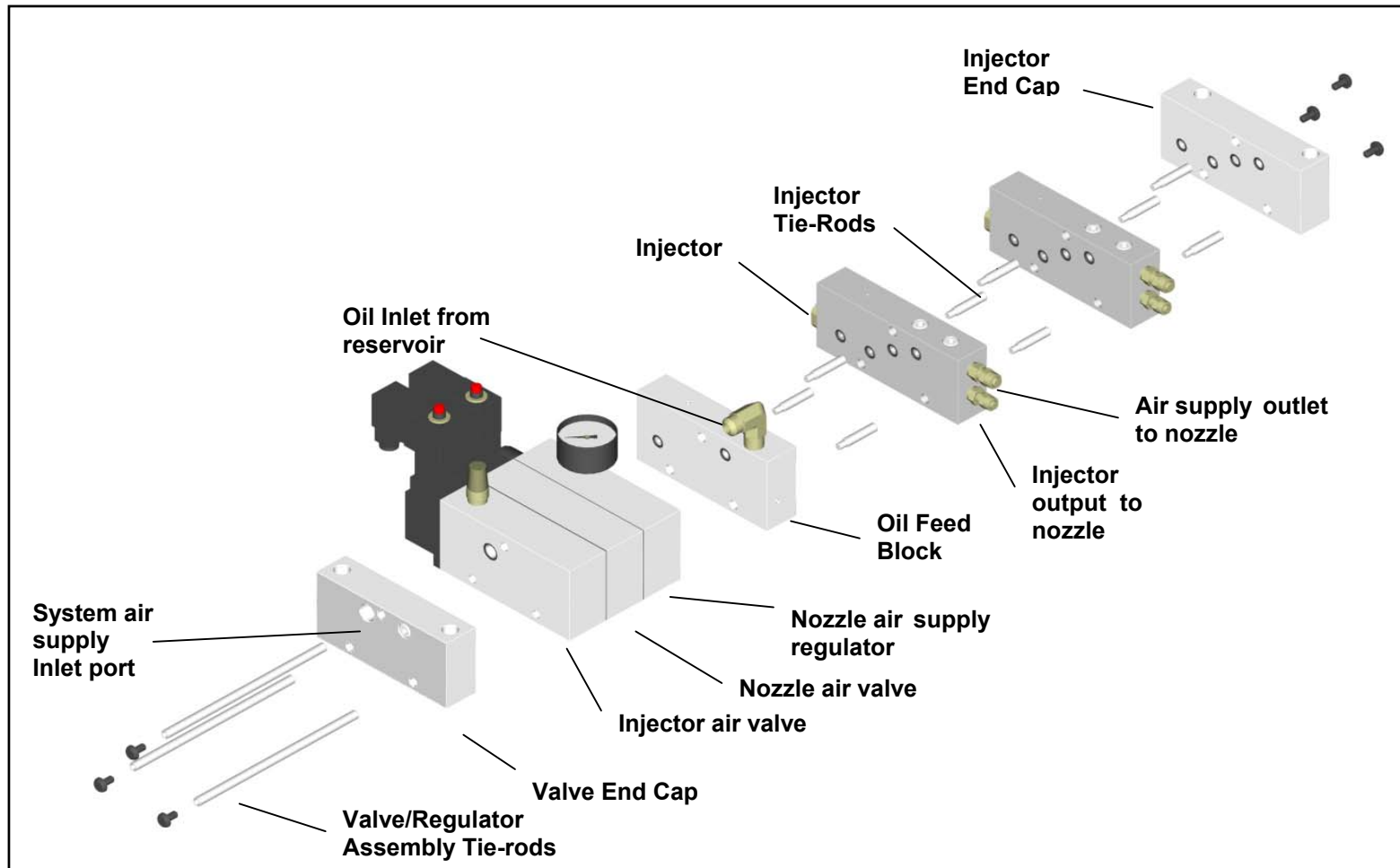

VS/VSR Technical Data

Operating Voltage	24 VDC
	120 VAC ~ 60 Hz.
	230 VAC ~ 50/60 Hz.

Solenoid Power Requirements	24 VDC 6 Watts
	120 VAC - 60 Hz. 7 Watts
	230 VAC - 50/60 Hz 7 Watts

Temperature Range:	-20 F to 120 F (7 C to 50 C)
---------------------------	------------------------------

Number of Injectors:	8
-----------------------------	---

Reservoir	
Capacity	4000 ml (244 in ³)
Tube Material:	Acrylic
Seal Material:	Buna N
Filter:	100 mesh (150 micron)

Level Switch	
Material:	Buna N
Max. switching power:	70 VA
Max. switching current:	0.7 Amp
Switch contact (dry state)	SPST - N.C.

Lubricant Range:	100-2000 SUS
-------------------------	--------------

Injector Output	
#570-10000	0-0.015 ml (.001 in ³)
#570-10002	0-0.060 ml (.004 in ³)

Inlet Air pressure	4.5 - 8.3 bar (65-120 psi)
---------------------------	----------------------------

Air filter micron rating:	5 micron
----------------------------------	----------

Air Inlet port	1/4" NPT
-----------------------	----------

Lines	
Nozzle Air Supply	1/4" O.D. Nylon
Min. bend radius	22 mm (0.88")
Working pressure	17.2 bar(250 psi) @ 23.9 C (75 F)
Burst pressure	68.9 bar (1000 psi) @ 23.9 C (75 F)

Nozzle Oil Supply	3/16" O.D. Nylon
Min. bend radius	19 mm (0.75")
Working pressure	13.8 bar(200 psi) @ 23.9 C (75 F)
Burst pressure	55.1 bar (800 psi) @ 23.9 C (75 F)

VS/VSR Spare Parts List

VS Assembly Spare Parts	Orsco Item No.
110/120 AC Injector Valve Block	549-20000
240/220 AC Injector Valve Block	549-20001
24 VDC Injector Valve Block	549-20002

110/120 AC Nozzle Air Valve Block	549-20004
240/220 AC Nozzle Air Valve Block	549-20005
24 VDC Nozzle Air Valve Block	549-20006

110/120 AC Valve Coil	549-20009
240/220 AC Valve Coil	549-20011
24 VDC Valve Coil	549-20010

Solenoid Kit	549-20012
Spool Assembly Kit	549-20013
170/VS/VSR Seal Kit (See below)	570-10084

Valve/Regulator Tie Rod	785-43300
Regulator Tie Rod (Dual Regulator Option only)	785-43200

Regulator Block Assembly	549-99416
Gauge: 30 PSI	495-09185
Gauge: 15 PSI	291-09237
Gauge: 60 PSI	495-91310
Gauge: 160 PSI	105-09190-0624

Injector Manifold End Cap	116-43500
Valve Manifold End Cap	116-43501
Oil Feed Block	116-43600

Injector Components	
Injector (Half-Drop)	570-10000
Injector (Double-Drop)	570-10002
Injector Tie Rod	785-43100

Filter/Reservoir Components	
Filter/Regulator, 5 micron	549-99313
5 Micron Filter Element	549-90013
Pressure switch (preset @ 50 psig)	549-11013
Reservoir Base Assembly (w/ Float sw.)	570-89472
Reservoir Float Switch	090-07145
Reservoir Seals (Buna)	567-99244
(Viton, EPDM Seals available upon request)	

Fittings	
Nylon Tube Push In Fittings	
3/16" Tube x 1/8" NPT Straight	549-11055
1/4" Tube x 1/8" NPT Straight	549-11047

Nylon Tube Compression Fitting	
3/16" Tube x 1/8" NPT Straight	575-12602
1/4" Tube x 1/8" NPT Straight	575-12670-0982

Steel Tube Fittings (Mat'l: Carbon Steel)	
1/8" Steel Tube x 1/8" NPT Straight	344-96554
1/4" Steel Tube x 1/8" NPT Straight	035-98588

Steel Tube Fittings (Mat'l: Stainless Steel)	
1/8" Steel Tube x 1/8" NPT SS Ftg.	999-99312
1/4" Steel Tube x 1/8" NPT SS Ftg.	999-99313

Tubing	
3/16" O.D. Nylon (per foot)	565-19185
1/4" O.D. Nylon (per foot)	565-19040-2950

170/VS/VSR Seal Kit includes:
 (2) Reservoir Seals
 Valve Interface Seals
 Injector Interface Seals (for 8 injectors)

Recommended Spare Parts	Quantity
Valve Coils	2
Injector (Complete Assembly)	2
Air Filter Element: 5 micron	1
Reservoir Assembly (#570-89472)	1
Spare Fittings	2 each

We recommend these items relevant to your system.

Fig. 6: VS/VSR Cable Assemblies

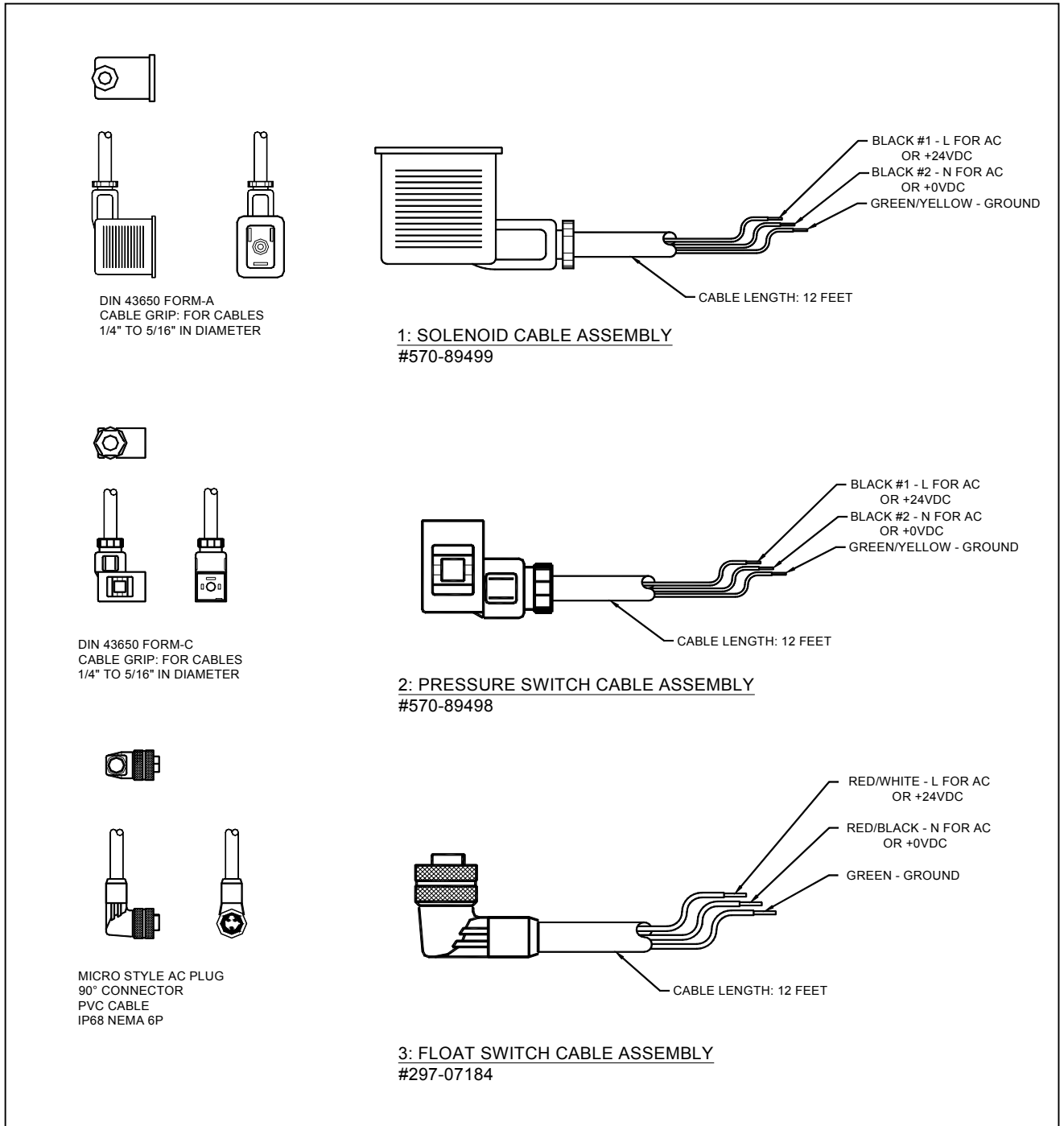

**120 VAC DIAGRAM
FOR REFERENCE ONLY**

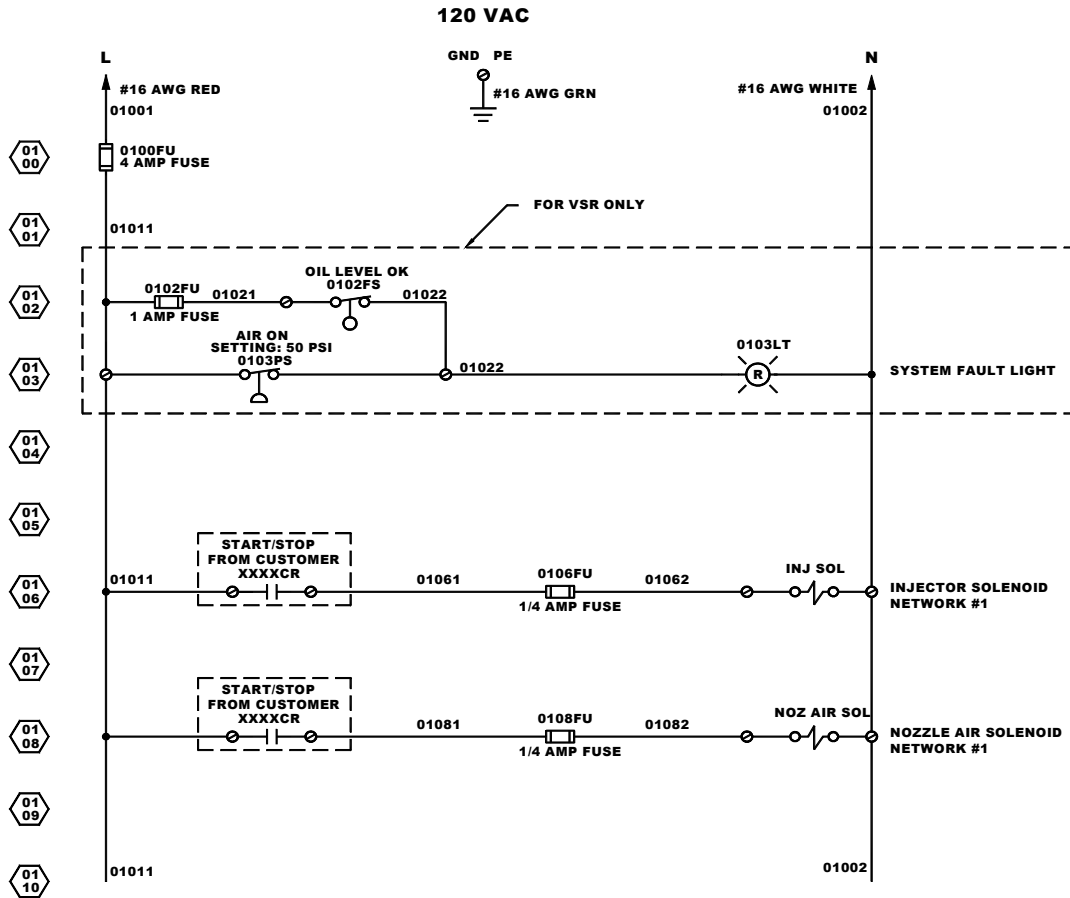

SEQUENCE OF OPERATIONS: NETWORK #1

- A. CUSTOMER CONTROLLER ENERGIZES INJECTOR SOLENOID (INJ SOL). THIS WILL ACTIVATE THE OIL INJECTOR AND DELIVER OIL INTO THE NOZZLE. SIMULTANEOUSLY, ENERGIZE THE NOZZLE AIR SOLENOID (NOZ AIR SOL). THIS WILL START AIR FLOW TO THE NOZZLE.**
- B. HOLD INJECTOR SOLENOID (INJ SOL) ENERGIZED FOR A MINIMUM OF 0.5 SECONDS, THEN DE-ENERGIZE. HOLD THE NOZZLE AIR SOLENOID (NOZ AIR SOL) ENERGIZED ACCORDING TO THE TIMING DIAGRAMS INDICATED AT FAR RIGHT FOR THE APPROPRIATE APPLICATION.**
- C. IF MORE OIL IS REQUIRED DURING THE SPRAY CYCLE TIME, RE-ENERGIZE THE INJECTOR SOLENOID (INJ SOL). THE FREQUENCY OF THE INJECTOR SOLENOID (INJ SOL) WILL DETERMINE THE TOTAL OIL VOLUME PER SPRAY CYCLE.**

DEVICE NOTES

- 1. 0102FS IS CLOSED BY LOW OIL IN THE RESERVOIR. N/C HELD OPEN BY OIL IN RESERVOIR.**
- 2. 0103PS IS CLOSED BY LOW AIR PRESSURE AT STATION. N/C HELD OPEN.**

**24 VDC DIAGRAM
FOR REFERENCE ONLY**

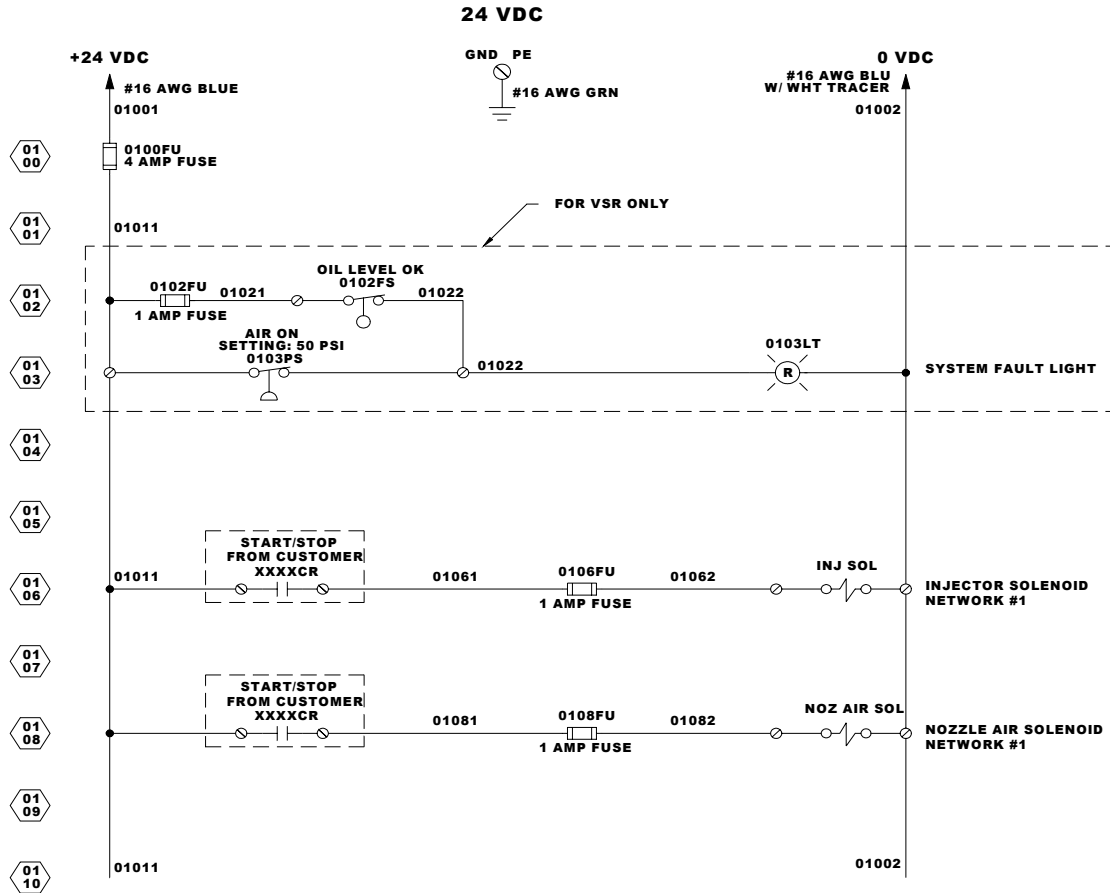

SEQUENCE OF OPERATIONS: NETWORK #1

- A. CUSTOMER CONTROLLER ENERGIZES INJECTOR SOLENOID (INJ SOL). THIS WILL ACTIVATE THE OIL INJECTOR AND DELIVER OIL INTO THE NOZZLE. SIMULTANEOUSLY, ENERGIZE THE NOZZLE AIR SOLENOID (NOZ AIR SOL). THIS WILL START AIR FLOW TO THE NOZZLE.
- B. HOLD INJECTOR SOLENOID (INJ SOL) ENERGIZED FOR A MINIMUM OF 0.5 SECONDS, THEN DE-ENERGIZE. HOLD THE NOZZLE AIR SOLENOID (NOZ AIR SOL) ENERGIZED ACCORDING TO THE TIMING DIAGRAMS INDICATED AT FAR RIGHT FOR THE APPROPRIATE APPLICATION.
- C. IF MORE OIL IS REQUIRED DURING THE SPRAY CYCLE TIME, RE-ENERGIZE THE INJECTOR SOLENOID (INJ SOL). THE FREQUENCY OF THE INJECTOR SOLENOID (INJ SOL) WILL DETERMINE THE TOTAL OIL VOLUME PER SPRAY CYCLE.

DEVICE NOTES

1. 0102FS IS CLOSED BY LOW OIL IN THE RESERVOIR. N/C HELD OPEN BY OIL IN RESERVOIR.
2. 0103PS IS CLOSED BY LOW AIR PRESSURE AT STATION. N/C HELD OPEN.

Notes